



HardiePlank® Cladding

Installation Guide

Facades That Last Longer™



JamesHardie

Contents

General	5
Tools & Accessories	6
Storage & Handling	8
Cutting	9
Painting	10
Preparation	12
HardieTrim® NT3® Profile Fixings	14
HardieTrim® NT3® Profile Installation	15
MetalTrim Installation	16
Ventilation	17
HardiePlank® Cladding Fixings	18
HardiePlank® Cladding Installation	19
Maintenance	21
Installation Drawings	22
General Arrangement: Horizontal Installation	23
Window Details: HardiePlank® On Edge	34
Window Details: With HardieTrim® NT3®	36
General Arrangement: Vertical Installation	38
Health & Safety	42
Always Remember To:	43



General

Overview

HardiePlank® cladding is an 8mm thick weatherboard plank, to be used as external or internal cladding for both new build and renovation projects. To complement the product, both fibre cement and metal trim profiles are available to finish corners, door and window frames.

Composition

HardiePlank cladding is made from the advanced, durable material fibre cement. Fibre cement comprises Portland cement, milled sand, cellulose fibres, water and selected additives.

Technical Information

HardiePlank cladding is available in two textures, cedar and smooth.

Cedar Texture



Smooth Texture



Smooth Trim



	HardiePlank® cladding	HardieTrim® NT3® profiles
Thickness	8mm	25mm
Length	3600mm	3655mm
Width	180mm	90mm, 140mm
Weight	11.2 kg/m ²	21.9 kg/m ² , 53.7/m ²

HardiePlank cladding and HardieTrim NT3 profiles have been assessed by the British Board of Agrément, and awarded BBA certificate number: No 04/4147. HardiePlank cladding conforms to Type A, Category 2 of the EN 12467.

HardieTrim NT3 profiles conform to Type A, Category 1 of the EN 12467. Both products are classified non-combustible: A2, s1-d0 in terms of fire rating, in accordance with EN13501-1.

Tools & Accessories

Supplied by James Hardie

EPDM Tape



To cover the vertical joints between planks and between planks and trims/windows/doors. Lengths of 20m in 60, 80, 100 and 120mm widths.

MetalTrim Profiles



For internal and external corners. Length 3000mm.

Ventilation Profiles



Starter and top ventilation profiles ensures the correct level of inlet and outlet ventilation. Available in 3 sizes to suit 25mm, 38mm and 50mm battens.

HardieClip™ Reinforcement Clip



A reinforcing clip for the nail fixing of HardiePlank® cladding. It ensures the correct positioning of the nail and the use of 600mm fixing centres in high wind pressure zones.

HardieGuillotine™ Cutting Tool



Use as the preferred cutting method.

HardieBlade® Saw Blade



Can also be used as the preferred cutting method. A diamond tipped saw blade producing low levels of dust. Available in 160mm, 190mm, 254mm or 305mm diametres.

James Hardie® Edge Coating



To touch-up cut edges and small damages. 1 litre / 500ml cans.

Supplied by James Hardie

Gecko Gauge



Gauges and supports cladding for one person installation.

Not supplied by James Hardie

Waterproof Membrane

The installation of a breather membrane acting as a vapour-permeable water-barrier is necessary for timber frame buildings or block walls where the wall is not considered waterproof. This barrier must be EN 13859:2005 requirements and have a vapour resistance less than 0.6MN.s.g⁻¹.

Battens

General: 50 × 25mm (to allow for a ventilation gap of min. 20mm).

Blockwork: 50 × 50mm (to accommodate for the siding fixing nail).

Counterbatten: Dimension ≥ 50mm × 25mm (for vertical installation of HardiePlank® cladding).

Fixings for HardiePlank® Cladding

The cladding does not require pre-drilling and can simply be nailed or screwed to the battens. Fixings must have suitable corrosion protection for the intended application. Check with your engineer where additional consideration must be made.

Nails: Ring shank nails of at least 50mm × 2.8mm and diameter head of 6.5mm. These nails should be manufactured according to EN10230-12000.

Where 50 × 25mm battens are installed on blockwork, ring shank nails of 2.65 × 30mm, ø 8mm can be used with hand nailing.

Screws: Screws must be a minimum of 35mm long, 4mm diameter shank with 8mm diameter self-embedding head.

Fixings for HardieTrim® NT3® Profiles

Second fix brad nail 50mm × 16g. The nails need to penetrate the battens by at least 20mm.

Jig Saw

For façade details. Tungsten carbide tipped for producing curves or cut-outs.

Saw Equipped with HardieBlade® saw blade and HEPA Extraction

To cut HardiePlank cladding and HardieTrim NT3 profiles to size.

Storage & Handling

Store HardiePlank® cladding and HardieTrim® NT3® profiles flat and keep dry prior to installation. Product stored outside should be covered with a waterproof covering, in addition to the product packaging to avoid contact with water and dust.

Wet products must not be installed. Installing wet cladding will result in shrinkage at butt joints. James Hardie accepts no responsibility for damage caused by improper storage and handling of the product.



Always carry planks with the edges held vertically, to avoid the planks bending.



The products are equipped with a PE film for protection of the surface during transportation, cutting and installation. PE is an environmentally friendly polymer, which can be recycled.

Cutting

As with all other building materials, safety precautions must be taken to avoid dust issues when cutting and drilling. Dust from fibre cement boards is characterized as mineral dust and EU-approved FFP2/3 respirators can be used in conjunction with the following cutting practices to further reduce dust exposure.

Cutting should always be undertaken outdoors

- Position cutting station so that wind will blow dust away from user and others in working area.
- Use one of the following methods based on the required cutting rate:

Preferred Cutting Method

HardieGuillotine™ or dust reducing circular saw equipped with a HardieBlade® saw blade and HEPA vacuum extraction.

Acceptable Cutting Method

Dust reducing circular saw with a HardieBlade® saw blade (only use for low to moderate cutting).

Minimum Cutting Method

(For low to moderate cutting only) Hand saw with hardened teeth.

- **NEVER** use a power saw indoors.
- **NEVER** use a circular saw blade that does not carry the James Hardie trademark.
- **ALWAYS** follow the tool manufacturer's safety recommendations.
- **NEVER** use a grinder or continuous rim diamond blade for cutting as they produce too much dust.
- When cleaning up debris, **NEVER** dry sweep as it may excite silica dust particles into the user's breathing area. Instead, damp debris down with a fine mist to suppress during sweeping, or use a HEPA vacuum.

Important Note: HSE approved respirators should be used in conjunction with above cutting practices to further reduce dust exposures. If concern still exists about exposure levels or you do not comply with the above practices, you should always consult a qualified industrial hygienist or contact James Hardie. For further information, refer to our Material Safety Data Sheet available at www.jameshardie.co.uk. Also refer to page 40 reference the inhalation of silica dust.

Painting

If cut to size the edges of the HardiePlank® cladding and HardieTrim® NT3® profiles must be sealed with the James Hardie® Edge Coating, prior to installation. Edge Coating should be applied with a small paint pad with, if available, a triangular shaped head as this gives the most control. Do not apply the Edge Coating to the face of the product. Wipe off any excess from the front face immediately.



The James Hardie® Edge Coating may also be used to deal with small scratches and marks less than 6mm. The paint should be used sparingly and restricted to the area of damage otherwise it may become visible. If the damage is still visible the plank should be replaced.



Preparation

Construction

James Hardie does not specify the fastening requirements for the framing to the building and as such would not accept liability for such structural elements. The attachment of the framing should be incorporated into the overall building design and should be approved by the responsible parties.

Structure

The structural wall to which HardiePlank® cladding is to be fixed must be of sufficient strength and stiffness to satisfy the requirements of the local building regulations. The wall may be of masonry or framed construction.

Waterproof Membrane

If required fix a waterproof membrane to the outer face of the structural wall, with an overlap between the layers of membrane of at least 150mm. Ensure the waterproof membrane is lapped to drain any water to the outside of the building. James Hardie will assume no responsibility for water infiltration.

Framing

Batten centres are typically 600mm reducing to 500mm or 400mm at the boundary areas of the building up to building height of 4 storeys. Seek advice from a professional engineer regarding batten centres as these correspond to the wind load calculated for the contract.

Frame type	Battens centres (mm)	Fixing type/dimensions (mm)	Fixings centres (mm)	Max wind pressure (kPa)
Timber battens (minimum 25 mm thick)	600	3.0×50 galvanised/ stainless steel nails ¹	600	1.7
Timber studs	600	2.8×51 Paslode nails ² with 0.5mm thick gauge steel clips ³	600	2.07
	400	2.8×51×7 Paslode D-head nails	600	1.87
	600	2.8×51×7 Paslode D-head nails	600	1.33
2.2mm thick Nvelop aluminium rails fixed to timber studs	600	3.5×4 Faynot stainless steel screws ⁴	600	1.53
Timber studs	600	4.0×35 wood screws ⁵	600	1.40

(1) Minimum head diameter 10mm.

(2) Minimum 6.5mm head diameter.

(3) 56×28×8.5mm, provided with 3×3mm diameter holes at 22mm centres and 6mm from the edge.

(4) Countersunk head screw.

(5) Minimum 8mm head diameter.

Framing Continued

The timber thickness should not be less than 25mm thick. When fixing over a masonry wall use a thicker batten to accommodate the 50mm cladding fixing nail.

The wall battens should be level. Irregularities in framing and sheathing can mirror through the finished application.

Counter battens: When there is a requirement for external insulation the main batten must be installed on a counter batten to maintain the air flow/ventilation behind HardiePlank® cladding. The counter batten dimension should be ≥ 50mm×25mm, fixed at ≤ 600mm to the main batten. The fixing centres of the counter batten to the wall are dependent on the wall unevenness. Distance between primary anchors ≤ 800mm.

EPDM Gasket

The EPDM gasket tape replaces the mastic seals in all areas where the planks abut each other or HardieTrim® NT3® profile. It provides additional weather protection to the battens to prevent them rotting prematurely. Install by stapling to the top of the batten, then allow the gasket roll to drop, take out any slack and place staples at regular intervals down its length. Trim to size.

Important note: Do not stretch the EPDM gasket as this could lead to it pulling over the staple fixings.

HardieClip™ Reinforcement Clip

Use this reinforcing clip for the nail fixing of HardiePlank cladding. It ensures the correct positioning of nail and the use of 600mm fixing centres in high wind pressure zones. Place the clip over the top of the plank with the short leg facing outward on the centre of the batten and apply a nail through the centre pre punched hole. At joints: place the clip centrally over two boards and fix using the two outside nail holes.

HardieTrim® NT3® Profile Fixings

Pre-drilling is not necessary; HardieTrim® NT3® profile can easily be gun nailed. Check the pressure of the gun. If incorrect the product can be damaged. Fix with second fix brad nail 50mm×16g. Profiles need to be flush nailed or overdriven (by 1mm max.) so nail heads only can be painted.

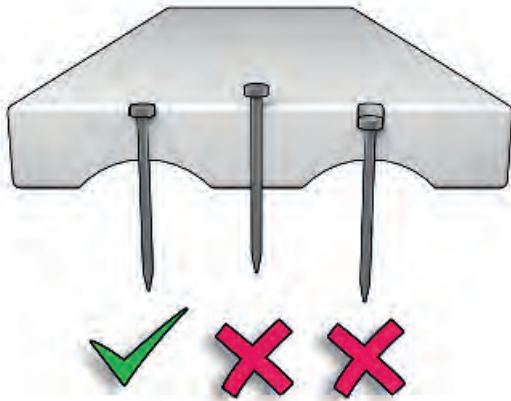

If you do not have access to a brad nail gun the HardieTrim NT3 profile can be installed with stainless steel screws. The screw size should be 3.5mm×50mm with a countersunk head. Pre-drill the HardieTrim NT3 profile with a 3.5mm masonry bit and countersink the hole. Install the screws 25mm down from the top edges and then in pairs every 400mm down the product. The screws should have their heads driven slightly below the surface of the product. Carefully fill the countersink with a suitable exterior grade filler, allow to fully cure before painting just the head area with James Hardie® Edge Coating, applied with an artist's brush. Do not overpaint onto the surrounding area, keep the paint to just the filled head of the screw.

HardieTrim® NT3® Profile Installation

HardieTrim® NT3® profiles should be pre-assembled on the ground, this will allow an easier and more level installation.

Fix the corner profiles at 400mm down the length, 25mm in at the ends and 12mm in down the long edges. Ensure the bottom of the trim overhangs the bottom of the batten by 10mm.



Where the cladding height is greater than the length of HardieTrim NT3 profile (3.65m) it will be necessary to butt joint corner trims. This should be done by offsetting the ends of the trim by 300mm to provide a staggered horizontal interlock and not a straight butt joint. Not only is the detail stronger, but it also is aesthetically more pleasing.

Refer to detail pages 26 and 27.

Important Note:

Make sure to leave the protective film on the profiles during installation. This will allow you to apply edge coat paint to the nail head. The protective film can be removed immediately after application or left on until other trades have completed their work.

MetalTrim Installation

Important note: MetalTrim corner profiles are to be installed vertically only.

Cutting MetalTrim

1. Cut the MetalTrim with a suitable saw or shears.
2. Ensure that the cuts are clean and straight.
3. Ensure that the trim is not damaged during the cutting operation.

Installation

Fix the trim with stainless steel nails. Ensure that you do not overdrive or underdrive nails.

When joining pieces of trim together ensure that the trim is correctly aligned prior to fixing. Pay attention to thermal expansion where exposure of the MetalTrim to sun is extreme. When fixing the trim, fix the trim at the top first, then the base then fix at remaining locations. Maximum spacing of fixings is 1.5m. It is imperative that the plastic protection is removed immediately after installation otherwise it will become trapped behind the cladding and be difficult to remove.

Refer to detail pages 28 and 29.

Ventilation

A free-flow ventilation gap of a minimum of 20mm should be provided between the cladding layer and the substrate.

It is critical that an air inlet and outlet gap of a minimum of 10mm is left at the base and at the roofline, also below and above doors/windows.

Use a perforated enclosure to prevent pests entering through the ventilation gap.



Key

Green: Air Inlet

Blue: Air Outlet

HardiePlank® Cladding Fixings

Pre-drilling is not necessary; HardiePlank cladding can easily be gun nailed. It is essential that the pressure of the gun is adjusted so the fixing will sit flush. If incorrect the product can be damaged and not hold sufficiently. Fix with a ring shank of at least 50mm x 2.8mm and 6.5mm diameter head.

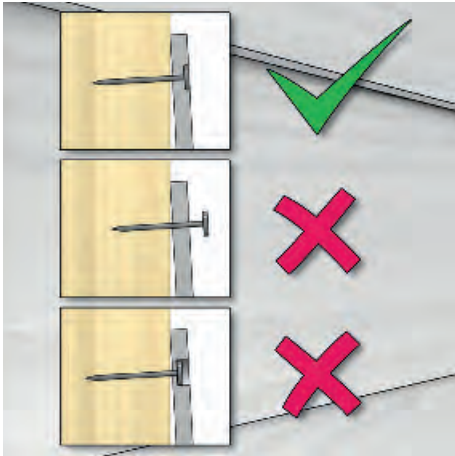

Fix the cladding to the vertical timber battens with one nail or screw on every batten. The centre line of the nail or screw should be 20-25mm below the top edge of the cladding. When fixing the ends of the cladding ensure the fixing is placed at 15mm from the edge.



HardiePlank® Cladding Installation

1. Clearances

Do not install James Hardie® products, such that they may remain in contact with standing water.

Install HardiePlank® cladding in compliance with local building regulations requirements for clearance between the bottom edge of the cladding and the adjacent finished grade. This is typically 150mm. Maintain a minimum 50mm clearance between HardiePlank cladding and roofs, paths, steps and driveways.

2. Horizontal Installation

2.1. Starter Ventilation Profile

The easiest way to ensure the correct detailing for the first plank is by installing the combined starter and ventilation profile. An alternative could be to cut a 30mm wide starter strip from a sheet of HardiePlank cladding to kick out the first plank to match the lap of the wall. Nail this along the front face of the battens so the lower edge of the starter strip lies along the line made by the bottom of the vertical battens. This provides the lap spacing for the first row of plank. The omission of this strip will result the “kick-out” on the wall appearing inconsistent in the second, third and fourth courses.

2.2. Fitting the first layer of HardiePlank cladding

Mark a line 170mm up from the lower edge of the starter strip. Ensure that this line is level. This will be the top of the first row of cladding. This spacing gives a 10mm drip edge at the lower edge of the cladding.

2.3. Second and subsequent layers of plank

The second row of HardiePlank® cladding is placed so that the lower edge of the second plank overlaps the top of the first plank by 30mm. It is important to carefully maintain this dimension throughout the construction of the wall.

A Gecko Gauge set to 150mm will help speed up the installation. Alternatively, measure 150mm up from the top edge of the plank and draw a line on the battens, this gives the position for the top edge of the next plank. It is advisable to check with a spirit level every 4 or 5 rows to ensure the planks level is maintained.

HardiePlank® Cladding Installation continued

2.4. Plank joints

Cut the cladding plank neatly so that it finishes at the centre line of the timber batten. Stagger the butt joints in an area of wall over two or more batten lines i.e. **avoid joints located directly in the same vertical line.** The cladding planks are butted in moderate contact to form the joint. Put an EPDM gasket underneath each joint. James Hardie believes it is good building practice to have 1mm joints around windows, doors and trim edges to allow for a degree of building movement and product tolerance. It also provides a natural vertical drain for rainwater.

2.5. Fixing the last plank

In most situations it is unlikely that the planks will exactly fit the wall height, in this case it will be necessary to cut the last plank down in width. Measure down from the underside of the soffit to the top of the previous plank and then add 20mm. **This will allow the correct overlap of 30mm and top ventilation gap of 10mm.**

3. Vertical Installation

HardiePlank® cladding can also be installed vertically. To facilitate vertical installation, counter battens should be installed horizontally over the vertical frame to support the vertical planks. HardiePlank cladding is installed at 120mm centres, such that these planks can be covered by a second layer of cladding which covers the first layer by 30mm at both sides. Use ring shank nails for the first layer of planks, starting at 15mm from the top of the batten. Use the same nails, but stainless steel, for the second layer, and start at 35mm from the top of the batten so nails will not coincide. Nails should be 15mm in from each vertical edge as this position places the fixing in the middle of the overlapped area.

Refer to detail pages 38 and 39.

4. Wall Penetrations

When a penetration in the wall is required for a pipe or tap for example, form a hole in the plank using a carbide tipped hole saw. Make the hole approx. 6mm larger than the diameter of the pipe. Seal between the fitting and the edge of the hole with a high quality exterior sealant. If the space between the fitting and the hole is too wide, use a polyethylene foam-backing rod to fill the major part of the gap. The remaining gap should be filled with sealant.

5. Load Bearing

HardiePlank cladding and HardieTrim® NT3® profiles are not intended as a load bearing or shear element in the wall construction. Items required to be attached to the wall should be supported directly by connections to the structural sheathing and/or framing members, not attached to the cladding or trim as the primary load-bearing elements.

Maintenance

Annual Inspection

Under normal atmospheric conditions HardiePlank® cladding does not require much maintenance to maintain its strength, properties and function. Environmental impacts may, however, influence the visual appearance of the facade cladding. Therefore, an annual inspection of the ventilation gaps, joints and fixings is a good idea. Detection and repair of possible damages ensure a longer life for the facade cladding.

Impact from Nature

The weather and nearby green plants may affect the appearance of the facade cladding. Pollution, dirt, leaves from trees, bushes and flowers will have an impact on the façades appearance. HardiePlank cladding is manufactured from weather resistant raw materials and will not be attacked by algae, rot and dry rot.

Coastal locations can be very aggressive due to salt laden moist air and wind-blown sand. It is recommended that the frequency of inspection procedures in such locations be increased and that any maintenance be enabled before damage occurs. It is recommended to pay attention to the corners of cladding namely around window, doors and the corners of façades particularly those facing the prevailing wind direction.

Repairing HardiePlank Cladding

HardiePlank cladding should be replaced by removing the damaged board, gently lifting the board immediately above and inserting the new board. The board is then fixed by face nailing through the top board.

Cleaning

HardiePlank cladding can be cleaned with cold or lukewarm water, if necessary with the addition of a mild household cleaning agent not containing solvents. Always start from the top with well-defined areas. Rinse with plenty of clean water until the facade is perfectly clean. Before cleaning full scale, it is recommended to test the chosen cleaning method on a smaller area to make sure it is likely to be successful. The cladding should be cleaned a minimum of once a year.

IMPORTANT NOTE: Do not use high pressure cleaning systems on fibre cement cladding, as this may damage the surface and paint finish.

Installation Drawings

General Arrangement: Horizontal Installation

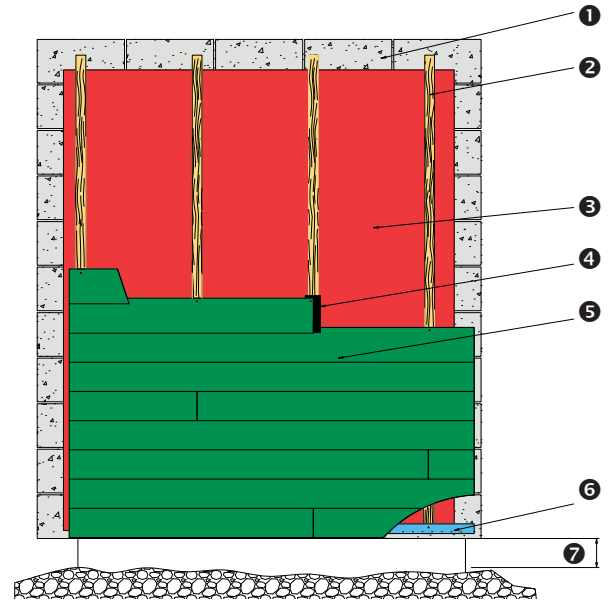

- ① Bricks / Masonry
- ② Vertically installed 50x50mm timber battens
- ③ Breather membrane
- ④ EPDM gasket at joint
- ⑤ HardiePlank® cladding
- ⑥ HardiePlank starter strip with ventilation
- ⑦ 150mm min.

Ground Level–Ventilation Detail

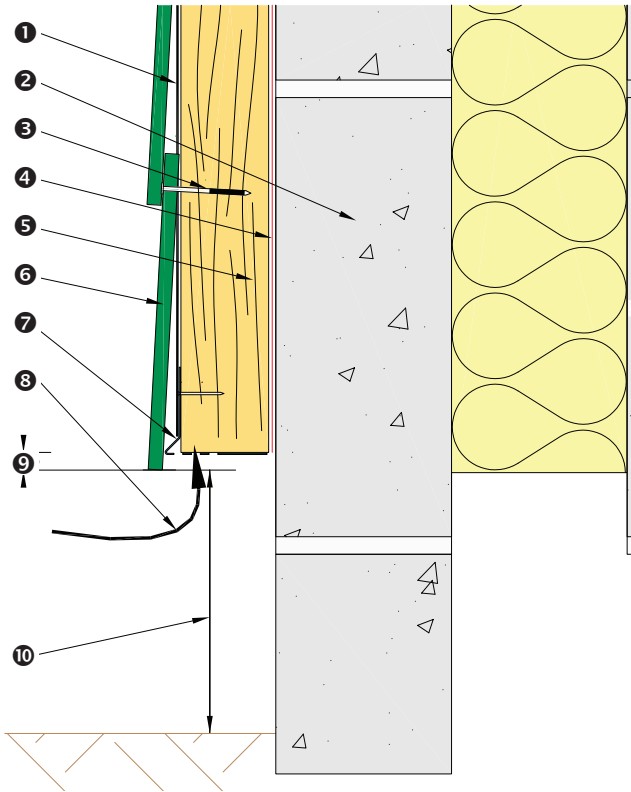

- ❶ EPDM
- ❷ Masonry
- ❸ 51 × 2.95mm fixing
- ❹ Breather membrane
- ❺ Timber battens 50 × 50mm
- ❻ HardiePlank® cladding
- ❼ HardiePlank starter strip with ventilation
- ❽ Ventilation path
- ❾ 10mm drip detail
- ❿ 150mm min.

Top of Cladding–Ventilation Detail

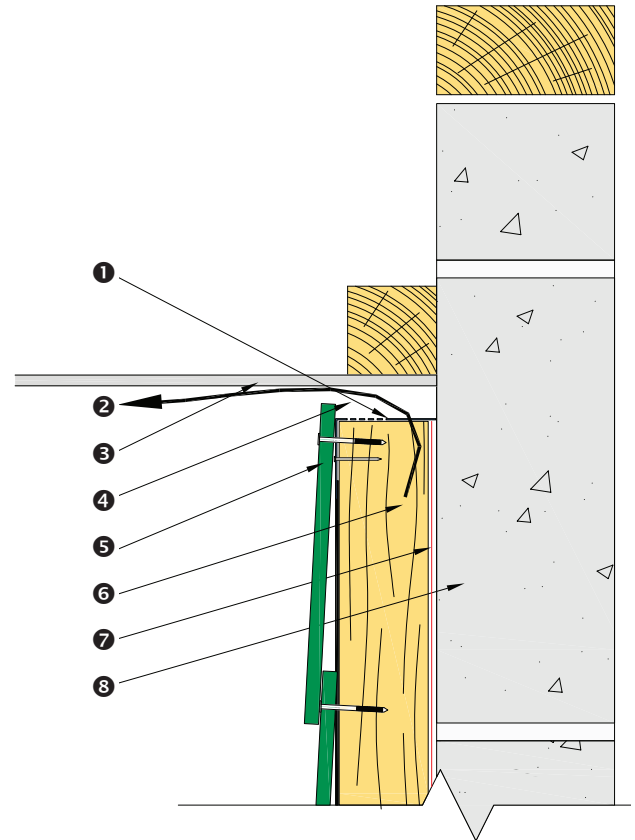

- ❶ HardiePlank® ventilation strip
- ❷ Ventilation path
- ❸ Soffit board
- ❹ 10mm ventilation gap
- ❺ HardiePlank cladding
- ❻ 50 × 50mm vertical timber framing batten
- ❼ Breather membrane
- ❽ Masonry

External Corner—HardieTrim® NT3®

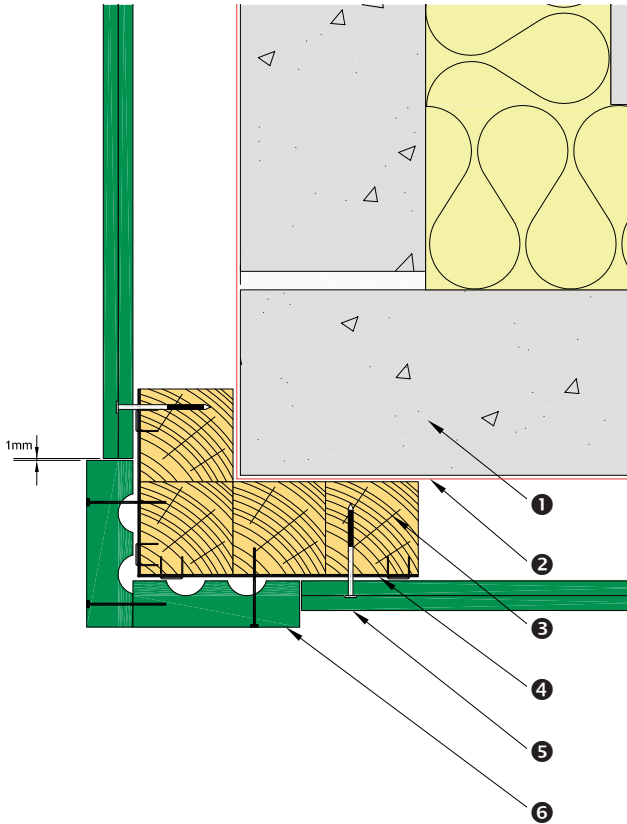

- ❶ Masonry
- ❷ Breather membrane
- ❸ Timber batten 50 × 50mm
- ❹ EPDM
- ❺ HardiePlank® cladding
- ❻ HardieTrim® NT3® profile

Internal Corner—HardieTrim® NT3®

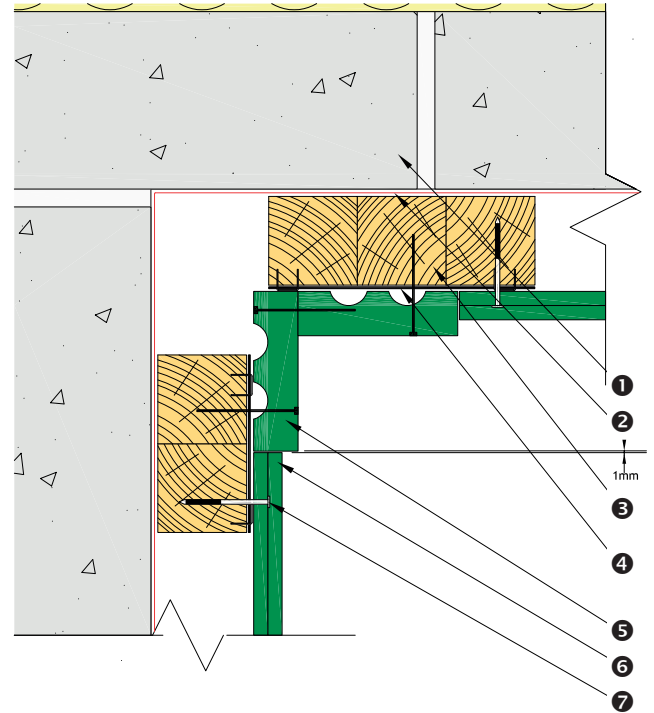

- ❶ Masonry
- ❷ Breather membrane
- ❸ Timber battens 50 × 50mm
- ❹ EPDM
- ❺ HardieTrim® NT3® profile
- ❻ HardiePlank® cladding
- ❼ 51 × 2.95mm fixing

External Corner–MetalTrim

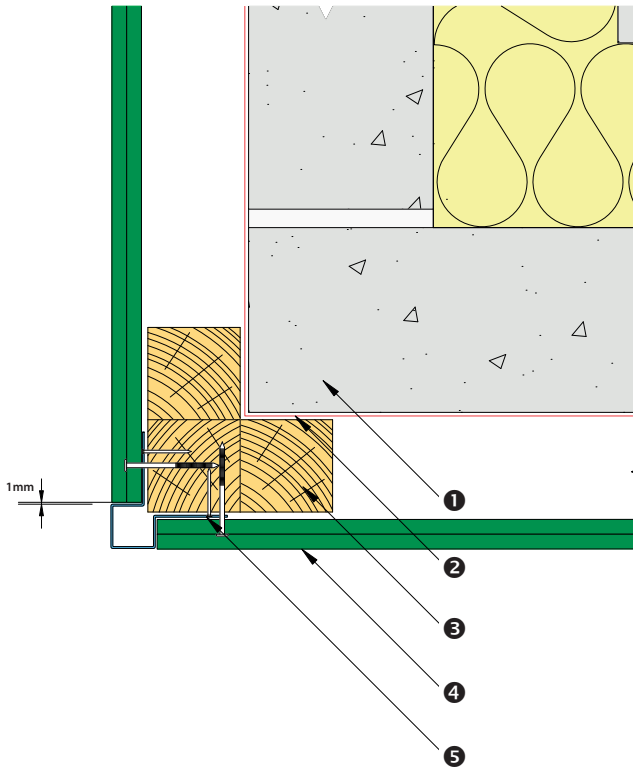

- ❶ Masonry
- ❷ Breather membrane
- ❸ Timber batten 50 × 50mm
- ❹ HardiePlank® cladding
- ❺ MetalTrim external corner profile

Internal Corner–MetalTrim

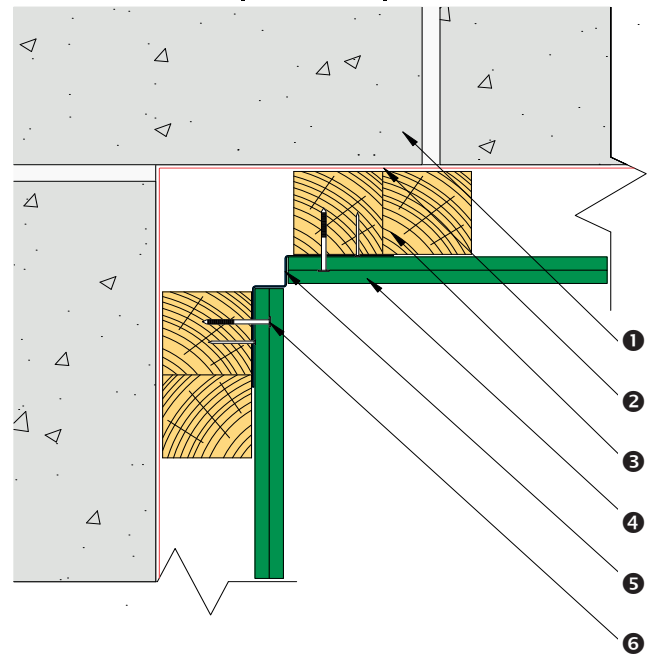

- ❶ Masonry
- ❷ Breather membrane
- ❸ Timber battens 50 × 50mm
- ❹ HardiePlank® cladding
- ❺ MetalTrim internal corner profile
- ❻ 51 × 2.95mm fixing

Gables

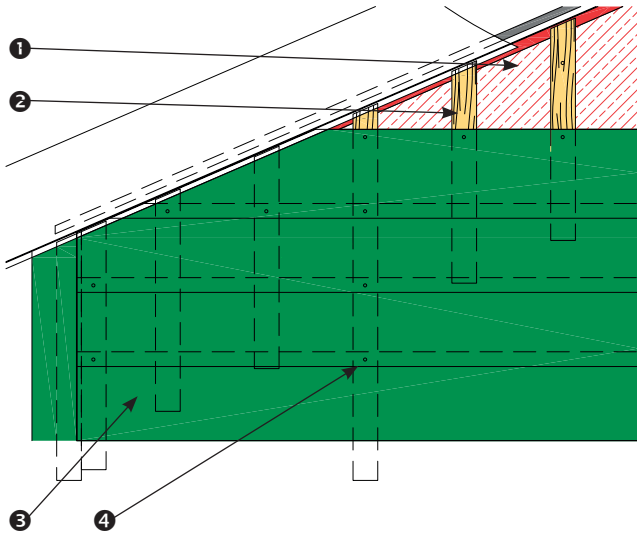

- ❶ Breather membrane
- ❷ Timber battens 50 × 50mm, 200mm centres
- ❸ HardiePlank® cladding
- ❹ 50mm fixing nail

Brick Dado Detail

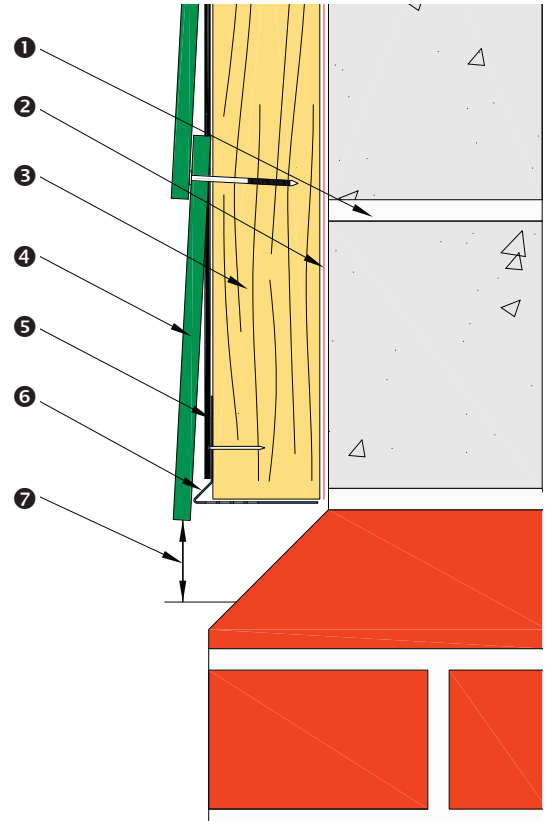

- ❶ Masonry
- ❷ Breather membrane
- ❸ Timber battens 50 × 50mm
- ❹ HardiePlank® cladding
- ❺ EPDM
- ❻ HardiePlank starter strip with ventilation
- ❼ 10mm drip detail

Expansion Gap

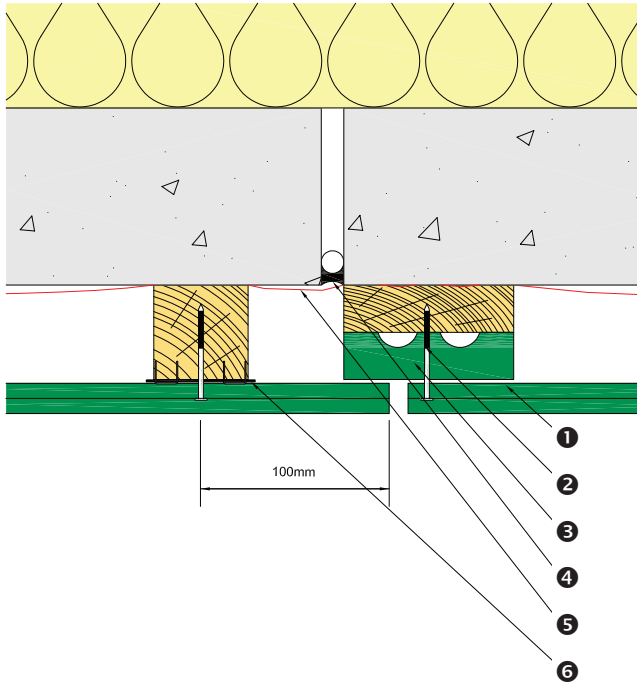

- ❶ HardiePlank® cladding
- ❷ 51 × 2.95mm fixing
- ❸ HardieTrim® NT3® profile
- ❹ Expansion gap
- ❺ Breather membrane
- ❻ EPDM

Abutment to Render

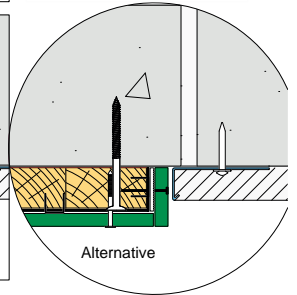
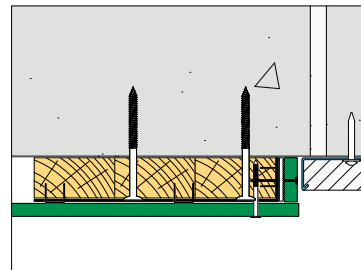
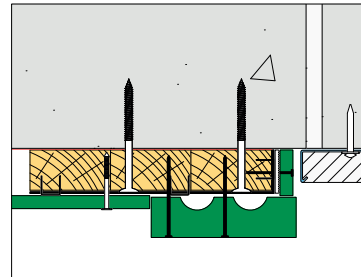
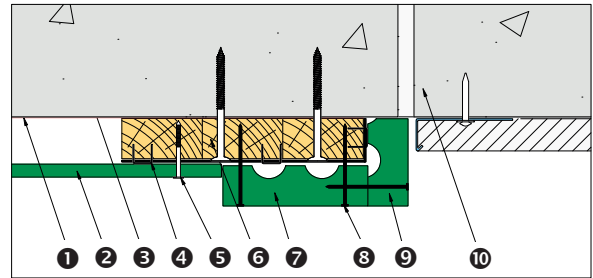

- ❶ Breather membrane
- ❷ HardiePlank® cladding
- ❸ Concrete block
- ❹ EPDM stapled to batten
- ❺ 51 × 2.95mm fixing
- ❻ 50 × 25mm timber
- ❼ 90 × 25mm HardieTrim® NT3® profile
- ❽ 51mm 16g fixing
- ❾ HardieTrim NT3 profile cut to fit
- ❿ Brickwork

Window Details: HardiePlank® On Edge



Reveal Detail

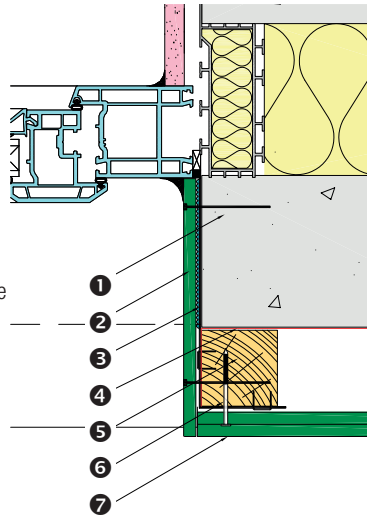

- 1 Masonry wall
- 2 HardiePlank® cladding on edge
- 3 EPDM
- 4 Breather membrane
- 5 Timber batten 50mm x 50mm
- 6 51mm x 2.95mm fixing
- 7 HardiePlank cladding

Window Head

- 1 Masonry wall
- 2 Breather membrane
- 3 Timber battens 50mm x 50mm
- 4 EPDM
- 5 HardiePlank® cladding
- 6 HardiePlank cladding starter strip with ventilation
- 7 HardiePlank cladding
- 8 Torx T20 screw

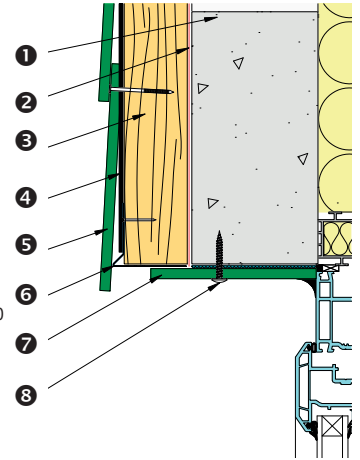

Window Cill

- 1 HardiePlank cladding
- 2 Top ventilation profile
- 3 Ventilation (min. 10mm)
- 4 51mm x 2.95mm fixing
- 5 HardiePlank cladding
- 6 EPDM
- 7 Timber batten 50mm x 50mm
- 8 Breather membrane

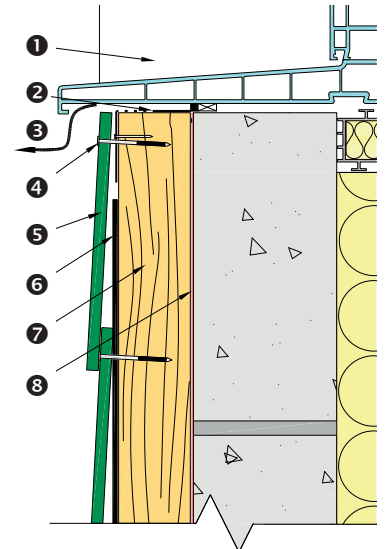

Window Details: With HardieTrim® NT3®



Reveal Detail

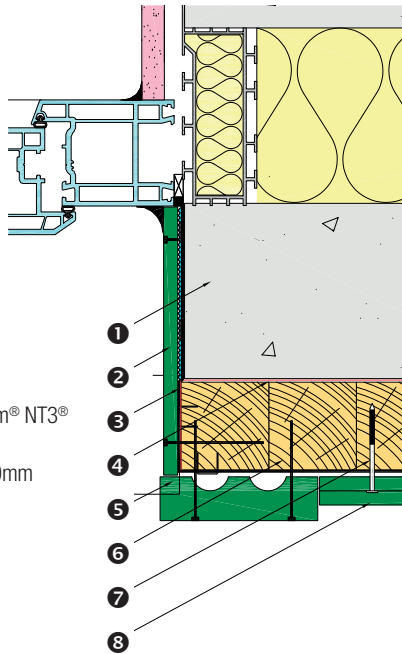

- 1 Masonry wall
- 2 HardiePlank® cladding
- 3 EPDM stapled to batten
- 4 Breather membrane
- 5 90mm x 25mm HardieTrim® NT3® profile
- 6 Timber batten 50mm x 50mm
- 7 51mm x 2.95mm fixing
- 8 HardiePlank cladding

Window Head

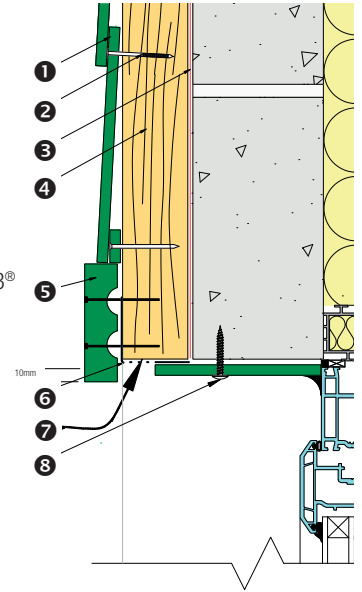

- 1 HardiePlank® cladding
- 2 51mm x 2.95mm fixing
- 3 Breather membrane
- 4 Timber batten 50mm x 50mm
- 5 90mm x 25mm HardieTrim® NT3® profile
- 6 HardiePlank ventilation strip
- 7 Ventilation strip
- 8 Torx T20 screw

Window Cill

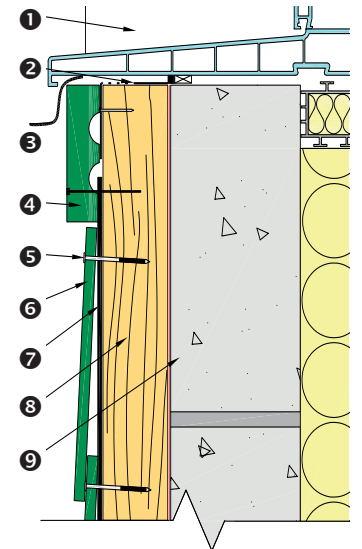

- 1 HardiePlank® cladding
- 2 HardiePlank ventilation strip
- 3 Ventilation (min. 10mm)
- 4 HardieTrim® NT3® profile
- 5 51mm x 2.95mm fixing
- 6 HardiePlank cladding
- 7 EPDM
- 8 Timber batten 50mm x 50mm
- 9 Masonry

General Arrangement: Vertical Installation

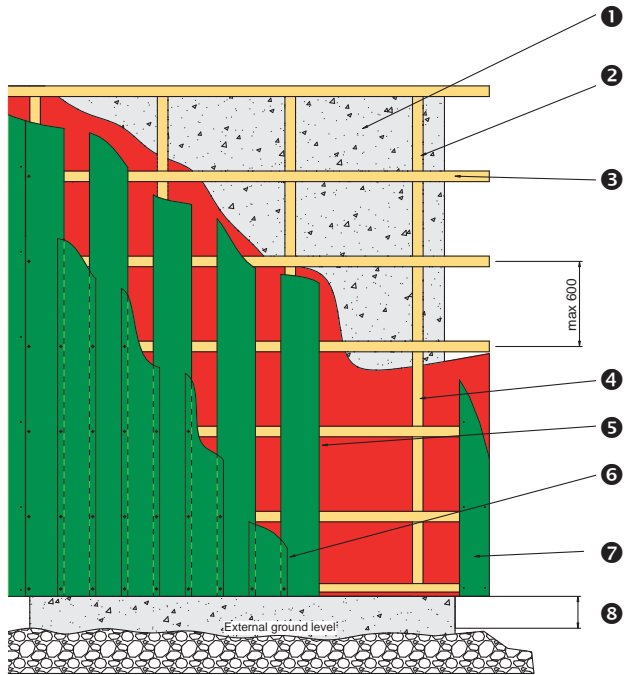

- ❶ Timber or masonry wall
- ❷ Vertically installed timber or steel framing battens set off structural wall face
- ❸ Horizontally installed timber or steel framing battens
- ❹ Install framing to comply with required wind loading (refer to table page 20) and provide sufficient framing for HardieTrim® NT3® profile
- ❺ Breather membrane under framing
- ❻ Vertically installed HardiePlank® cladding – 1st layer
- ❼ Vertically installed HardieTrim NT3 profile
- ❽ Minimum 150mm as per building regulations

Overlap Detail: Vertical Installation

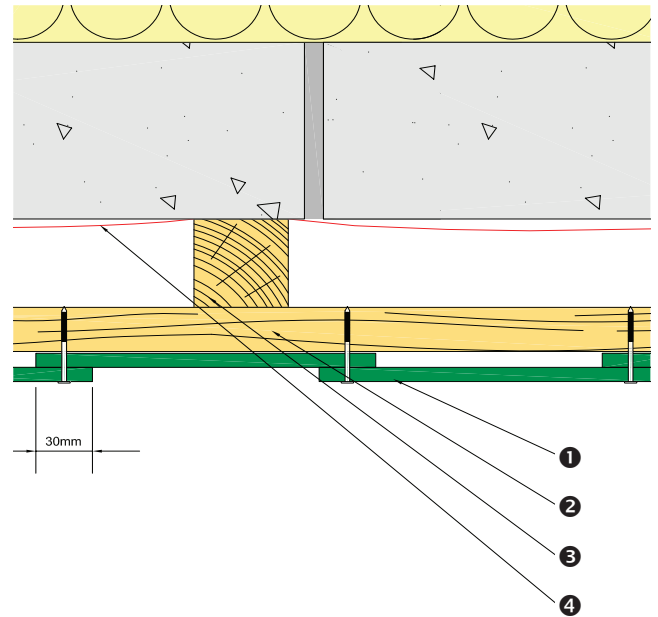

- ❶ HardiePlank® cladding
- ❷ 50 × 50mm horizontal timber batten
- ❸ 50 × 50mm vertical timber batten
- ❹ Breather membrane

Notes

Health & Safety

Warning-Avoid Breathing Silica Dust

James Hardie® products contain crystalline silica. This mineral is found everywhere in the world - often in the form of sand - and, therefore, commonly used in many construction products (for example brick, concrete, glass wool and abrasives). The mineral itself is inert, but certain building practices such as drilling, high speed cutting and abrading can release fine particulate dust which may constitute a health hazard.

Excessive or protracted inhalation of fine particle silica dust can lead to a lung disease called silicosis. There is also some evidence that it may increase the risk of lung cancer if inhaled for prolonged periods. Smoking may also exacerbate this risk. Like smoking, the risk from fine particle silica dust is time and concentration dependent.

Control

To suppress or to reduce excessive inhalation of fine particle silica dust the following steps should be taken to protect operatives who work with products containing silica dust:

- During fabrication operate outdoors or in well ventilated space in a separate area if available or away and down-wind from other operatives.
- Use low speed, low dust cutting tools – Score-and snap-knife, HardieGuillotine™, HardieBlade® saw blade fitted to a circular saw connected to a dust extraction HEPA filter vacuum cleaner (see James Hardie® tools).
- When cutting, drilling or abrading always wear a FFP2/3 dust control or full face mask adjusted and fitted in conformity with regulatory recommendations and affixed with CE marking and/or fully certified to the relevant EN standards if applicable.
- Keep the working environment clean and remove debris as soon as possible.
- At the end of the operation remove dust from clothes, tools and work area with a HEPA filter vacuum cleaner or damp with water to suppress the dust before sweeping.

Remember, James Hardie products are no more dangerous than many other building materials containing crystalline silica sand. We hope, through this information, to engage in effective education of the construction industry and build upon the requirements of national health and safety regulations. For more information, see our installation instructions and MSDS available on www.jameshardie.co.uk or call James Hardie.

Always Remember To:

1. Keep your James Hardie® products dry before installation. Refer to page 8.
2. Paint cut edges before installation. Refer to page 10.
3. Maintain a minimum 20mm free-flow ventilation gap between cladding and substrate. Refer to page 17.
4. Leave a 10mm air gap between last HardiePlank cladding and roofline. Refer to page 17
5. Ensure fixings are flush with the HardiePlank® cladding and 25mm down from top edge. Refer to pages 18.

For a full version of our 10 years limited warranty please visit:
www.jameshardie.co.uk/warranty

www.jameshardie.co.uk

T: 0800 068 3103

E: info@jameshardie.co.uk

www.jameshardie.co.uk

© 2015 James Hardie Building Products Ltd. All rights reserved.™ and ® denote trademarks of James Hardie Technology Ltd. A James Hardie 10 year limited warranty applies to all our all our fibre cement products. See www.jameshardie.co.uk/warranty for terms and conditions.

